

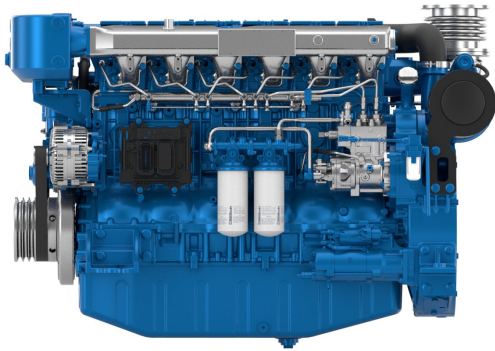

6M21.3

Propulsion Diesel Engine



Number of cylinders	6
Bore and stroke (mm)	127 X 165
Total displacement (L)	12.54
Cylinders	L6
Engine rotation	counter clockwise
Idle speed	700
Flywheel	14"
Flywheel housing	SAE 1

Customer benefits

Genuine marine design, our engine is designed specifically for Marine applications with Marine components, such as individual cylinder heads that make maintenance easier even in the smallest of engine rooms.

Global environment care with low exhaust emissions at any running cycle

Continuous compact power with reference performances in its category

Life cycle cost efficiency with extended maintenance intervals

Rated power

Duty	kW	HP	RPM	IMO	EPA
P1	330	450	1800	#	NO
P1	368	500	1800	II	NO
P2	405	550	1800	II	NO
P3	441	600	2100	II	NO

	P1	P2	P3
Application	Unrestricted Continuous	Heavy	Intermittent
Engine load variations	Very Little To None	Continuous	Important
Average Engine load factor	80-100%	30-80%	50%
Annual working time	More Than 5000 H	3000 -5000 H	1000 - 3000 H
Time at full load	Unlimited	8h Each 12h	2h Each 12h

P1 Continuous Duty

- Deep sea trawlers
- Shrimps trawlers
- Sea going tug boats
- River tug boats
- Push boats
- Freighters
- Dredges
- LCT
- Ferries

P2 Heavy Duty

- Deep sea trawlers
- Shrimps trawlers
- Sea going tug boats
- River tug boats
- Push boats
- Freighters
- Dredges
- LCT
- Ferries

P3 Intermittent Duty

- Seasonal passenger vessels
- Fishing boats
- Pilot boats
- Commercial pleasure boats
- Pump boats
- Displacement sailboats
- Trawlers
- Bow thrusters

P4 Light Duty

- Private pleasure boats
- Multi-hull pleasure boats
- Survey or rescue fast vessels
- Military fast vessels.

P5 High performance Duty

- Private pleasure boats
- Multi-hull pleasure boats

Dimensions and dry weight (mm/kg)

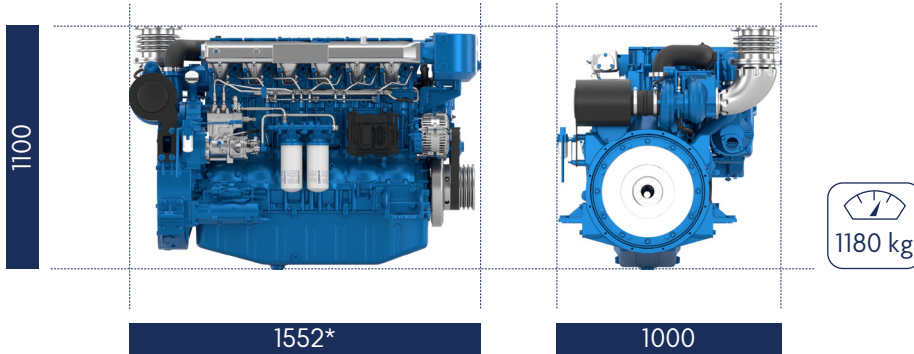

* 1442 from flywheel

Standard equipment

Cooling System

Two - stage cooling circuit with built - in HT thermostatic valve
Integrated fresh water expansion tank
High efficiency tubestack heat exchanger
Gear driven centrifugal fresh water pump
Self priming raw water pump with rubber impeller

Lubrication System

Full flow lube oil filters duplex type
Fresh water cooled lube oil cooler intergrated in cylinder block

Fuel System

Common-rail electronic injection
High pressure pump with double walled high pressure pipes
Fuel oil filter duplex type
External fuel pre-filter with water separator

Intake Air and Exhaust System

Double flow raw water cooled intake air heat exchanger module
High efficiency dry turbocharger
Water cooled exhaust manifold

Electrical System

Voltage: 24V DC insulated
Electrical starter
120A battery alternator

Optional Equipment

Not available at product launch

Power definition

(Standard ISO 3046/1 - 1995 (F))

Reference conditions

Ambient temperature	25°C / 77°F
Barometric pressure	100 kPa
Relative humidity	30%R
Raw water temperature	25°C / 77°F

Fuel oil

Relative density	0,840 ± 0,005
Lower calorific power	42 700 kJ/kg
Consumption tolerances	+ 5%
	(DIN ISO 3046-1)
Inlet limit temperature	35°C / 95°F

Our ratings also comply with classification societies maximum temperature definition without power derating.

Ambient temperature	45°C / 113°F
Raw water temperature	32°C / 90°F