

# 6M16

Variable Speed Engine

Engine Model	Rated Power	Peak Torque	Displacement	Cylinders	Voltage	Aspiration	Coupling		Throttle
							FWH	FW	
6M16V4D0	190 kW@2200 rpm	1266 Nm@ 1200 rpm	9.7L	L6	24V	T/A-A	SAE1	14"	Mechanical
6M16V2D0	255 kW@ 2200 rpm	1385 Nm@ 1400 rpm	9.7L	L6	24V	T/A-A	SAE1	14"	Mechanical

NA=Natural Aspirated, T=Turbocharged, T/A-A=Turbocharged & Air to Air aftercooled, T/A-W=Turbocharged & Air to Water aftercooled

## 6M16V4D0 - Torque Curve

rpm	Nm	kW
2201	830	191
2100	883	194
2001	942	197
1900	994	198
1800	1052	198
1700	1110	198
1600	1150	193
1500	1187	186
1400	1226	180
1301	1252	170
1200	1266	159
1100	1115	128
1000	1054	110
900	1058	100
800	1062	89
750	1062	83

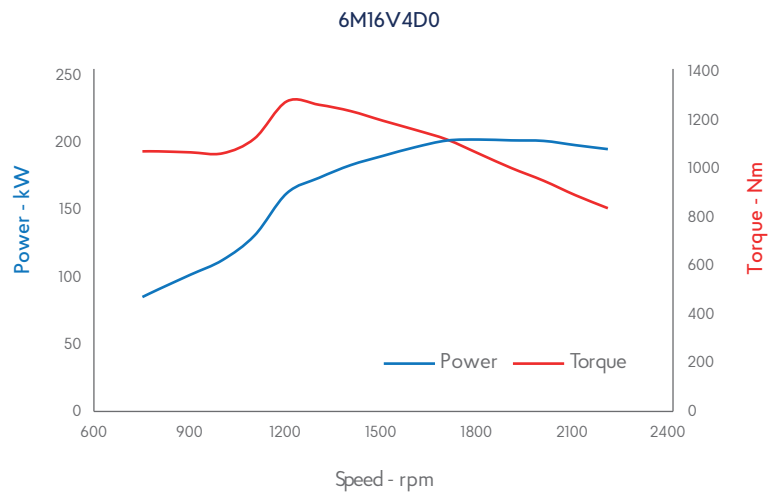

## 6M16V2D0 - Torque Curve

rpm	Nm	kW
2200	1108	255
2100	1152	253
2000	1216	255
1900	1264	252
1800	1306	246
1700	1339	238
1600	1376	231
1500	1382	217
1400	1385	203
1300	1370	187
1200	1311	165
1100	1213	140
1000	1091	114
900	981	93
800	874	73
750	818	64

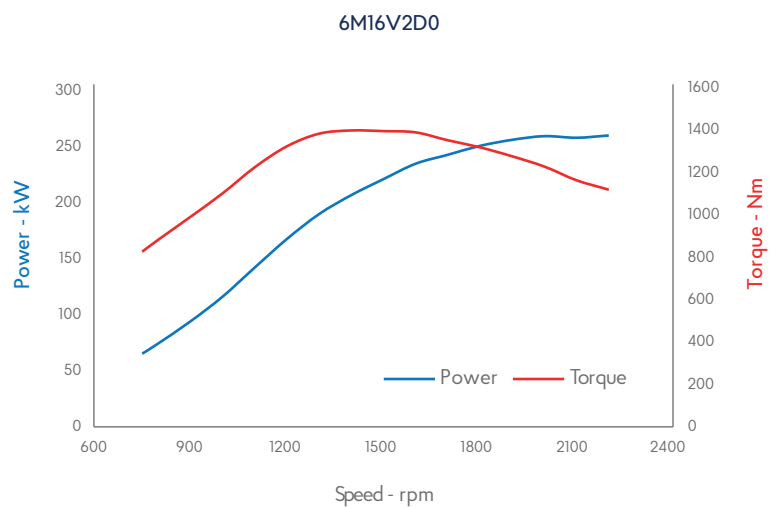



## Customer benefits

**Optimized for Variable Speed:** Delivers efficient performance across a wide range of operating speeds for both stationary and mobile applications.

**Effortless Maintenance:** Minimizes downtime with easy access to service.

**Fuel Versatility:** Engineered to handle the realities of varying fuel quality.

**Unmatched Peace of Mind:** Backed by a best-in-class warranty of 2 years / 2500 working hours for peace of mind.

## Dimensions and dry weight

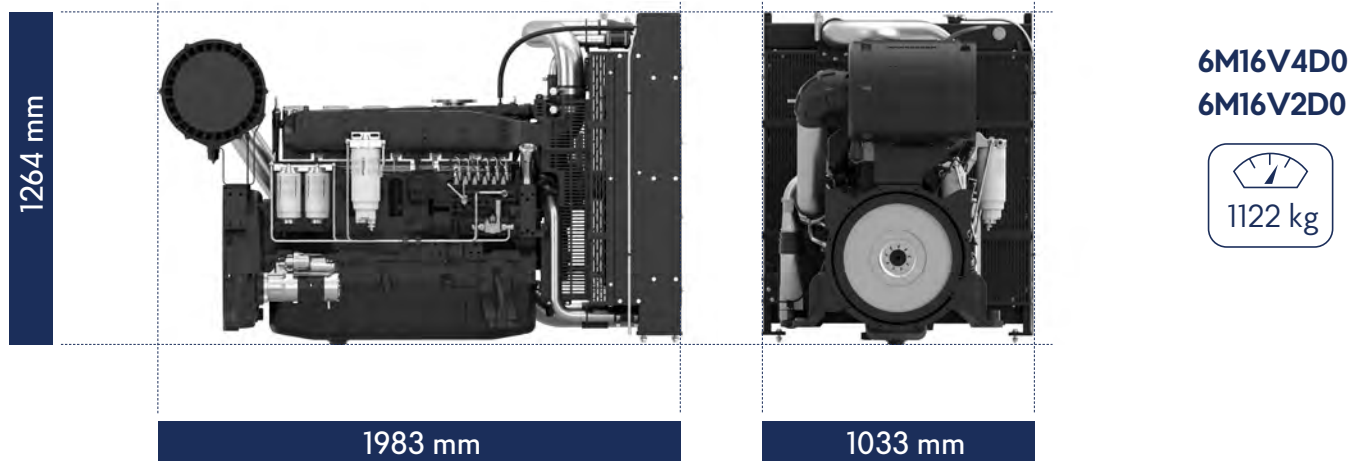

## Standard equipment

### Engine and block

Cast iron block  
One-piece forged crankshaft  
Separate cast iron cylinder heads and wet liners  
Aluminum alloy pistons with oil cooling gallery

### Cooling system

Radiator and hoses supplied directly mounted on the engine  
Thermostatically-controlled system with belt driven coolant pump & pusher fan

### Lubrication system

Flat bottom large capacity oil pan  
Spin-on full-flow lube oil filter

### Fuel system

Optimum performance and efficient use of fuel for continuous duty  
Duplex fine filter for better efficiency

### Air intake and exhaust system

Special rear mounted air filter with restriction indicator  
Exhaust manifold shield for heat isolating