

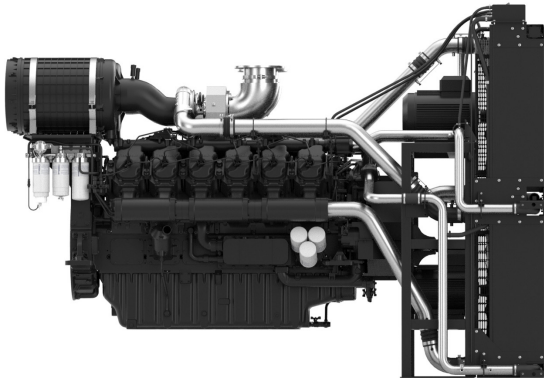

# 12M33

PowerKit Variable Speed Engine



Bore x Stroke (mm)	150 x 185
Displacement (L)	39.2
N° of Cylinders	12
Cylinders Arrangement	At Vee
Fuel System	Common Rail/ Mechanical
Governor (Gov.)	ECU/ Electronic
Aspiration (Asp.)	T/A-A

### Customer Benefits

**Variable speed engines** optimised for use between 800 and 2200 rpm

**Straightforward** mechanical injection for easy maintenance

**Strong tolerance** to varying fuel quality

**Peace of mind** with best-in-class warranty of 2 years/2500 working hours

Variable Speed Engine	12M33								
Model	Maximum Power	Max Speed	Max Torque @Speed		Disp.	Asp.	Coupling		Throttle
	kW	RPM					FWH	FW	
12M33V4D0	1007	1900	6200	1400	39.2L	T/A-A	SAE0	18"	E

### Ratings definitions

#### Continuous Power (COP)

Continuous Power is the maximum power available for an unlimited period of use at a constant load factor. No overload capability is allowed.

### Dimensions and dry weight (mm/kg)

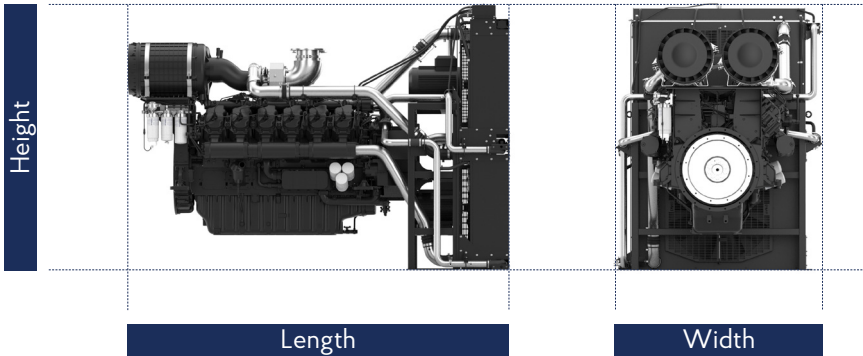

Variable Speed Engine	Dimensions and dry weights including radiator			
Model	L (mm)	W (mm)	H (mm)	Weight (Kg)
12M33V4D0	3592	2242	2243	3420

\* Dimensions are including the radiator

## Standard equipment

### Engine and block

Cast iron gantry type structure block  
One-piece forged crankshaft  
Separate cast iron cylinder heads and wet liners  
Aluminum alloy pistons with oil cooling gallery

### Cooling system

Radiator and hoses supplied directly mounted on the engine  
Thermostatically-controlled system with belt driven coolant pump and pusher fan

### Lubrication system

Flat bottom large capacity oil pan  
Spin-on full-flow lube oil filter

### Fuel system

Optimum performance and efficient use of fuel for continuous duty  
Duplex fine filter for better efficiency

### Air intake and exhaust system

Special rear mounted air filter with restriction indicator  
Exhaust manifold shield for heat isolating

### Electrical system

12V DC electric starter motor and battery charging alternator for 1500 rpm engines  
24V DC electric starter motor and battery charging alternator for 1800 rpm engines

### Flywheel and housing

SAE 3 flywheel housing and 11.5" flywheel for 1500 rpm  
SAE 1 flywheel housing and 14" flywheel for 1800 rpm