

12M26

PowerKit Variable Speed Engine

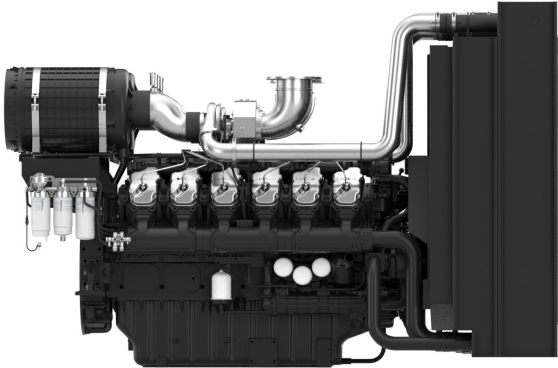

| | |
|-----------------------|------------|
| Bore x Stroke (mm) | 150 x 150 |
| Displacement (L) | 31.8 |
| N° of Cylinders | 12 |
| Cylinders Arrangement | At Vee |
| Fuel System | Mechanical |
| Governor (Gov.) | Electronic |
| Aspiration (Asp.) | T/A-A |

Customer Benefits

Variable speed engines optimised for use between 800 and 2200 rpm

Straightforward mechanical injection for easy maintenance

Strong tolerance to varying fuel quality

Peace of mind with best-in-class warranty of 2 years/2500 working hours

| Variable Speed Engine | 12M26 | | | | | | | | |
|-----------------------|---------------|-----------|-------------------|------|-------|-------|----------|-----|----------|
| Model | Maximum Power | Max Speed | Max Torque @Speed | | Disp. | Asp. | Coupling | | Throttle |
| | kW | RPM | | | | | FWH | FW | |
| 12M26V2D0 | 780 | 1800 | 5680 | 1200 | 31.8L | T/A-A | SAE0 | 18" | M |

Ratings definitions

Continuous Power (COP)

Continuous Power is the maximum power available for an unlimited period of use at a constant load factor. No overload capability is allowed.

Dimensions and dry weight (mm/kg)

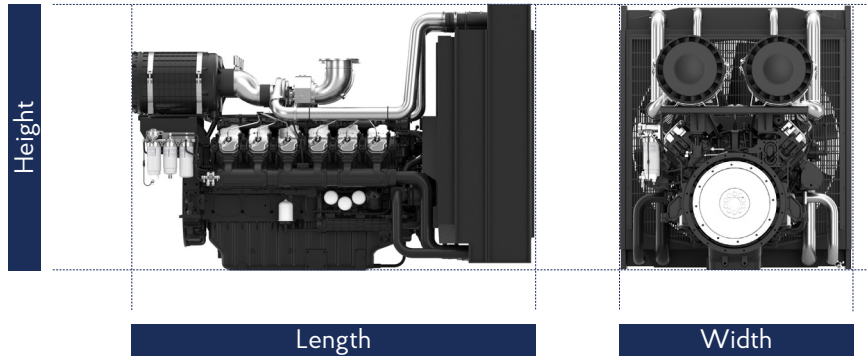

| Variable Speed Engine | Dimensions and dry weights including radiator | | | |
|-----------------------|---|--------|--------|-------------|
| Model | L (mm) | W (mm) | H (mm) | Weight (Kg) |
| 12M26V2D0 | 3162 | 1748 | 2150 | 2910 |

* Dimensions are including the radiator

Standard equipment

Engine and block

Cast iron gantry type structure block
 One-piece forged crankshaft
 Separate cast iron cylinder heads and wet liners
 Aluminum alloy pistons with oil cooling gallery

Cooling system

Radiator and hoses supplied directly mounted on the engine
 Thermostatically-controlled system with belt driven coolant pump and pusher fan

Lubrication system

Flat bottom large capacity oil pan
 Spin-on full-flow lube oil filter

Fuel system

Optimum performance and efficient use of fuel for continuous duty
 Duplex fine filter for better efficiency

Air intake and exhaust system

Special rear mounted air filter with restriction indicator
 Exhaust manifold shield for heat isolating

Electrical system

12V DC electric starter motor and battery charging alternator for 1500 rpm engines
 24V DC electric starter motor and battery charging alternator for 1800 rpm engines

Flywheel and housing

SAE 3 flywheel housing and 11.5" flywheel for 1500 rpm
 SAE 1 flywheel housing and 14" flywheel for 1800 rpm