

6W126

Genset Diesel Engine

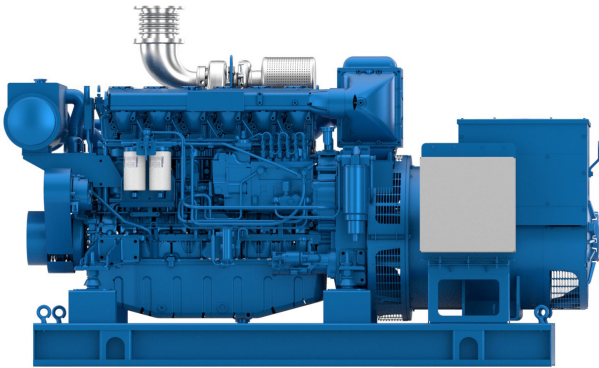

Number of cylinders	6 in line
Bore and stroke (mm)	126 X 155
Total displacement (L)	11.6
Compression ratio	18/1
Engine rotation	counter clockwise
Idle speed	700
Flywheel	SAE 11.5"
Flywheel housing	SAE 14"

Customer benefits

Continuous compact power with reference performances in its category

Easy service with accesible components and unit cylinder heads

Simple technology with common rail injection

Life cycle cost efficiency with extended MTBO (Mean time between overhauls)

6W126					Fuel consumption									Emissions	
Ratings					@ 100%			@ 75%			@ 50%			IMO	EPA
Rating	Hz	kVA	kWe	RPM	kWm	g/kWh	l/h	kWm	g/kWh	l/h	kWm	g/kWh	l/h		
PRP	50	330	264	1500	281	201	68	211	199	51	141	202	35	II	II
PRP	60	350	280	1800	297	200	72	223	197	53	149	202	36	II	II

Generator Sets Engines

Power Class		Definition
PRP	Prime Power	Unrestricted running time Time at full load ≤ 500hrs/year Load variation ≤ 75% of rated power 10% overload 1hr/12hrs

Dimensions and dry weight (mm/kg)

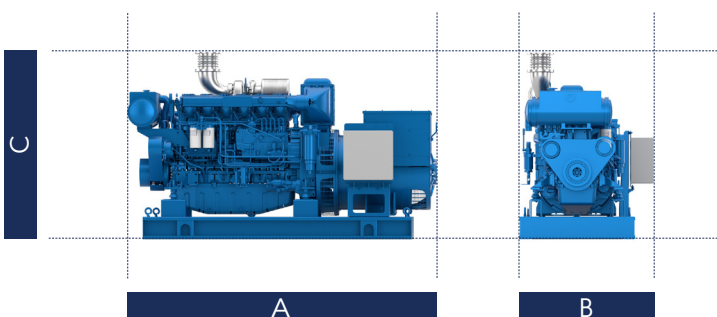

Genset	A	B	C	Dry weight
340 kVA @ 50 Hz	2607	1156	1390	2402
350 kVA @ 60 Hz	2607	1156	1390	2402

Standard equipment

Cooling System	Two - stage cooling circuit with built - in HT thermostatic valve Integrated fresh water expansion tank High efficiency tubular heat exchanger Gear driven centrifugal raw water pump Self priming raw water pump with bronze impeller
Lubrication System	Full flow lube oil filters duplex type Fresh water cooled lube oil heat exchanger
Fuel System	Common-rail electronic injection High pressure pump with shielded high pressure injection rail and pipes Fuel oil filter duplex type External fuel pre-filter with water separator
Intake Air and Exhaust System	Double flow raw water cooled intake air heat exchanger module High efficiency dry turbocharger with ball bearing technology Two Stage Turbocharging system
Electrical System	Voltage: 24V DC insulated Electrical starter 190A battery alternator

Optional Equipment	Wet exhaust PTO elastic coupling Additional pulley Electric drain system Standard PTO for hydraulic pump Different alternators possible - including 12V Electrical rotary actuator
---------------------------	------------------------------------------------------------------------------------------------------------------------------------------------------------------------------------------------------

Power definition

(Standard ISO 3046/1 - 1995 (F))

Reference conditions

Ambient temperature	25°C / 77°F
Barometric pressure	100 kPa
Relative humidity	30%R
Raw water temperature	25°C / 77°F

Fuel oil

Relative density	0,840 ± 0,005
Lower calorific power	42 700 kJ/kg
Consumption tolerances	+ 5%
	(DIN ISO 3046-1)
Inlet limit temperature	35°C / 95°F

Our ratings also comply with classification societies maximum temperature definition without power derating.

Ambient temperature	45°C / 113°F
Raw water temperature	32°C / 90°F