

6M33.3

Common rail diesel engine, 2-stage turbocharging

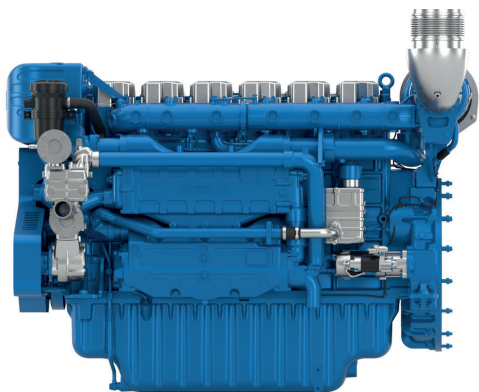

Number of cylinders	6 in line
Bore and stroke (mm)	150 x 185
Total displacement (L)	19.8
Engine rotation	counter clockwise
Idle speed (rpm)	700
Flywheel housing	SAE 0
Flywheel	SAE 18"

Customer benefits

Genuine marine design with simple solutions and routine maintenance accessibility

Continuous compact power with top-tier performance in category

Global environmental care: low exhaust emissions, noise reduction, and controlled fuel consumption

Latest safe technology integration: electronic injection dynamic redundancy, high-efficiency ball bearing turbocharger

Emphasis on life cycle cost efficiency with extended MTBO and modular design reducing components and interfaces

Rated power - Fuel consumption

Duty	kW	HP	RPM	Fuel consumption			IMO
				Optimum value	Rated power		
					g/kWh	g/kWh	
P1	552	720	1600	198	135	198	II
	552	780	1800	201	136	201	II
P2	574	800	1600	198	139	198	II
	574	850	1800	200	141	200	II
P3	670	911	1900	205	179	206	II
P4	750	1020	2000	201	203	201	II

Standard equipment

Dimensions and dry weight (mm/kg)

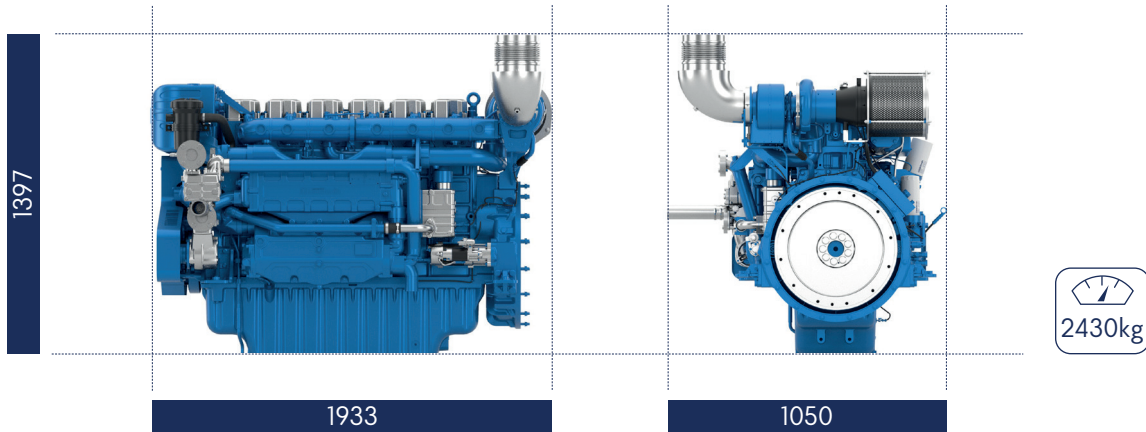

	P1	P2	P3	P4
Application	Unrestricted	Continuous (Heavy)	Intermittent	Light
Engine load variations	Not important	Important	Important	Very important
Average Engine load factor	80-100%	30-80%	60%	60%
Annual working time	5000 - 7000h	3000-5000h	1000-3000h	Less than 1500h
Time at full load	12h each 12h	8h each 12h	2h each 12h	1h each 12h

P1 Continuous Duty

- Deep sea trawlers
- Shrimps trawlers
- Sea going tug boats
- River tug boats
- Push boats
- Freighters
- Dredges
- LCT
- Ferries

P2 Heavy Duty

- Deep sea trawlers
- Shrimps trawlers
- Sea going tug boats
- River tug boats
- Push boats
- Freighters
- Dredges
- LCT
- Ferries

P3 Intermittent Duty

- Seasonal passenger vessels
- Fishing boats
- Pilot boats
- Commercial pleasure boats
- Pump boats
- Displacement sailboats
- Trawlers
- Bow thrusters

P4 Light Duty

- Private pleasure boats
- Multi-hull pleasure boats
- Survey or rescue fast vessels
- Military fast vessels.

P5 High performance Duty

- Private pleasure boats
- Multi-hull pleasure boats

Standard equipment

Engine & Block

Cast iron cylinder block, with replaceable cylinder liners
Separate cast iron cylinder heads
Replaceable valves guides and seats
Steel forged crankshaft with 7 bearings
Lube oil cooled light steel piston with 3 high performance piston rings

Cooling System

Two - stage cooling circuit with built - in HT thermostatic valve
Integrated fresh water expansion tank
High efficiency tubular heat exchanger
Gear driven centrifugal raw water pump
Self priming raw water pump with bronze impeller

Lubrication System

Full flow lube oil filters duplex type
Fresh water cooled lube oil heat exchanger

Fuel System

Common-rail electronic injection
High pressure pump with shielded high pressure injection rail and pipes
Fuel oil filter duplex type
External fuel pre-filter with water separator

Intake Air and Exhaust System

Double flow raw water cooled intake air heat exchanger module
High efficiency dry turbocharger with ball bearing technology
Two Stage Turbocharging system

Electrical System

Voltage: 24V DC insulated
Electrical starter
190A battery alternator

Optional Equipment

Wet exhaust
PTO elastic coupling
Additional pulley
Electric drain system
Standard PTO for hydraulic pump
Different alternators possible - including 12V
Electrical rotary actuator

Performance

P1 552@1600rpm

Torque

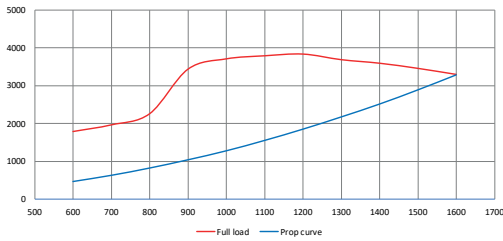

Power

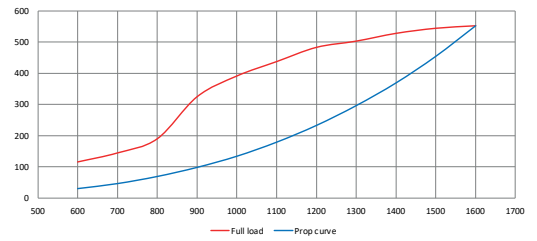

BSFC (L/h)

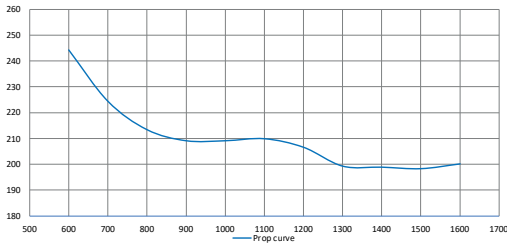

BSFC (g/kWh)

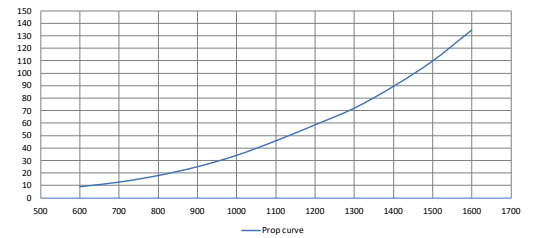

P1 552@1800rpm

Torque

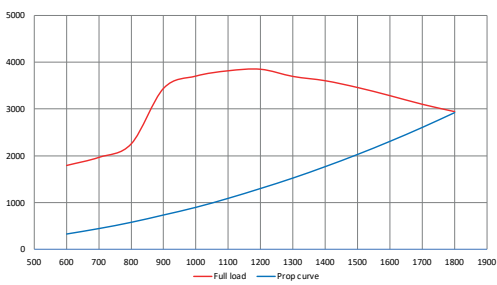

Power

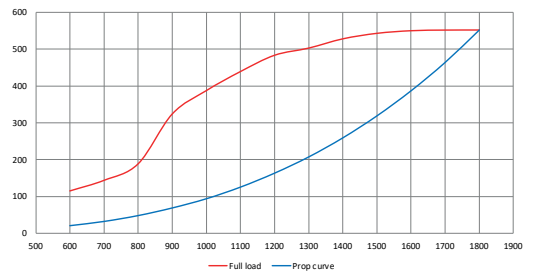

BSFC (L/h)

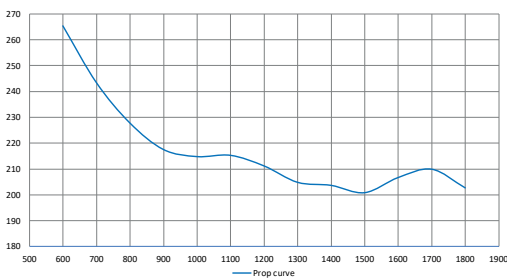

BSFC (g/kWh)

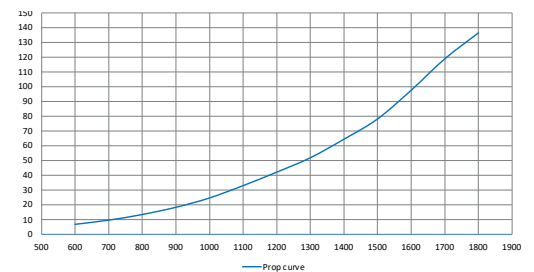

Performance

P2 574@1600rpm

Torque

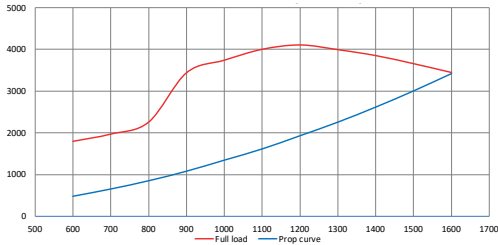

Power

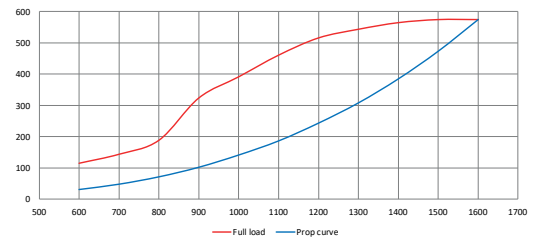

BSFC (L/h)

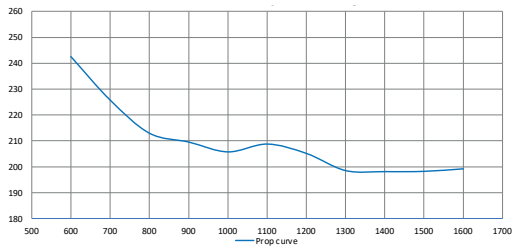

BSFC (g/kWh)

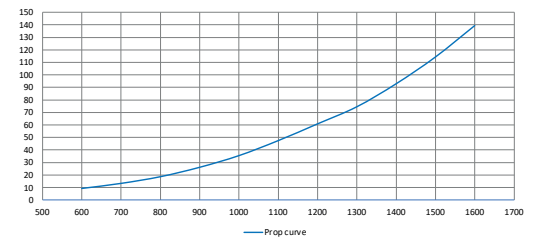

P2 574@1800rpm

Torque

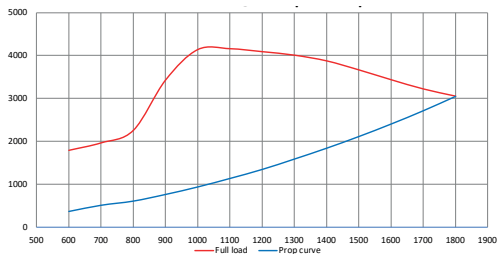

Power

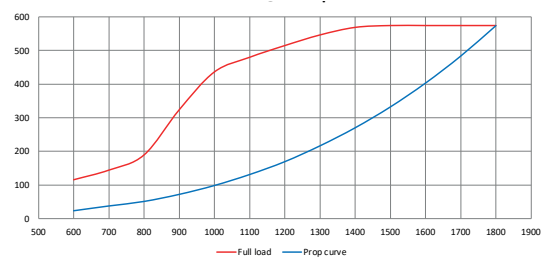

BSFC (L/h)

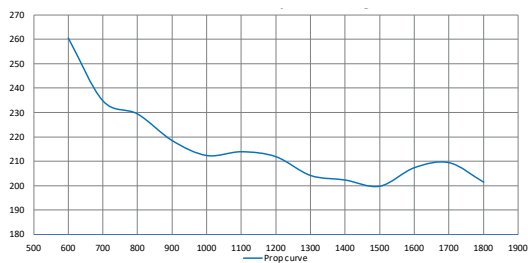

BSFC (g/kWh)

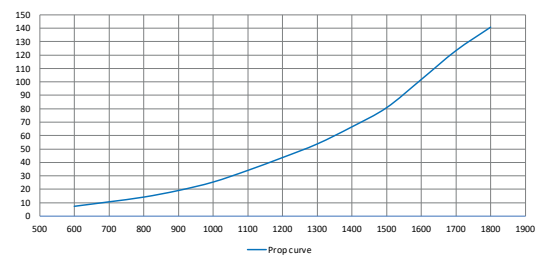

Performance

P3 670@1900rpm

Torque

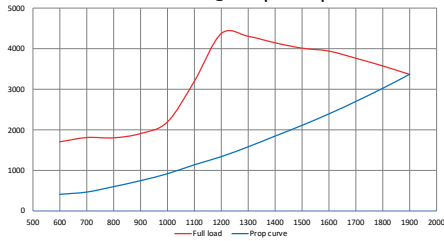

Power

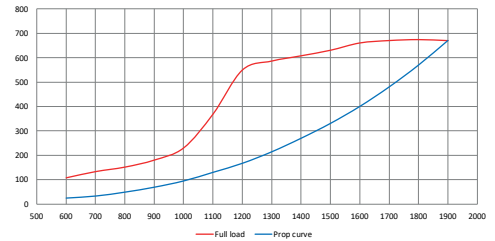

BSFC (L/h)

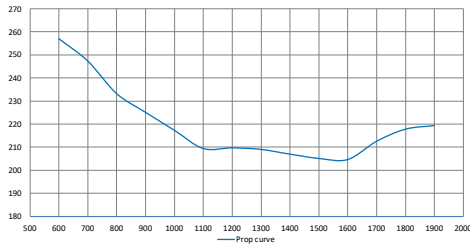

BSFC (g/kWh)

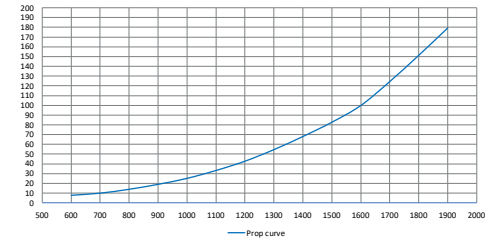

P4 750@2000rpm

Torque

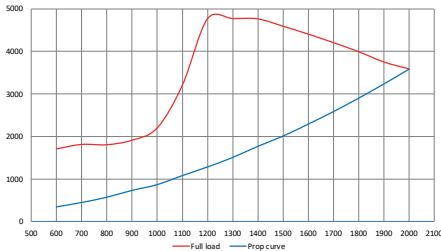

Power

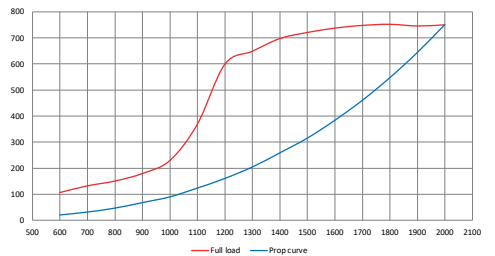

BSFC (L/h)

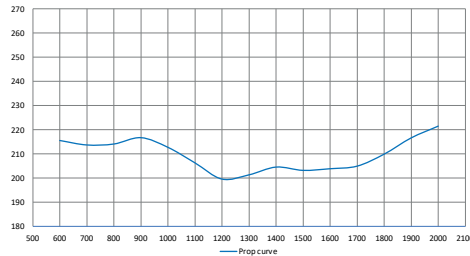

BSFC (g/kWh)

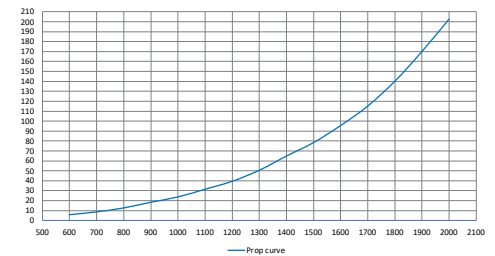

Power definition

(Standard ISO 3046/1 - 1995 (F))

Reference conditions

Ambient temperature	25°C / 77°F
Barometric pressure	100 kPa
Relative humidity	30%R
Raw water temperature	25°C / 77°F

Fuel oil

Relative density	0,840 ± 0,005
Lower calorific power	42 700 kJ/kg
Consumption tolerances	+ 5%
	(DIN ISO 3046-1)
Inlet limit temperature	35°C / 95°F

Our ratings also comply with classification societies maximum temperature definition without power derating.

Ambient temperature	45°C / 113°F
Raw water temperature	32°C / 90°F

 **MOTEURS**
Baudouin



Baudouin.com