

6M33.3

Common rail diesel engine

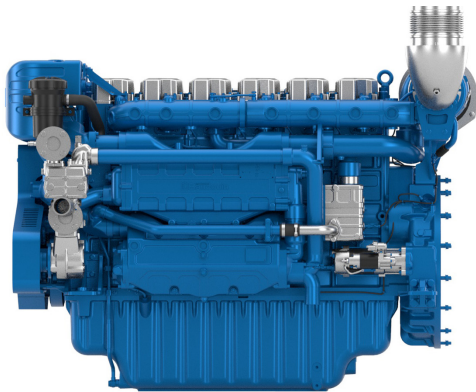

Number of cylinders	6
Bore and stroke (mm)	150 x 185
Total displacement (L)	19.6
Engine rotation	counter clockwise
Idle speed (rpm)	700
Flywheel housing	SAE 0
Flywheel	SAE 18"

Customer benefits

Genuine marine design with simple solutions and routine maintenance accessibility

Continuous compact power with top-tier performance in its category

Global environmental care: with low exhaust emission at any running cycle

Latest safe technology integration: electronic injection dynamic redundancy, high-efficiency ball bearing turbocharger, integrated circuits with 0 flexible hoses, and more

Emphasis on life cycle cost efficiency with extended MTBO and modular design reducing components and interfaces

Rated power - Fuel consumption

Duty	kW	HP	RPM	Fuel consumption			IMO
				Optimum value	Rated power		
					g/kWh	g/kWh	
P1	552	750	1600	199	203	137	II-III
	552	750	1800	203	211	142	II-III
P2	574	780	1600	200	202	142	II-III
	574	780	1800	205	210	147	II-III
P3	670	911	1900	207	215	176	II-III
P4	750	1020	2000	209	224	205	II-III

Standard equipment

Dimensions and dry weight (mm/kg)

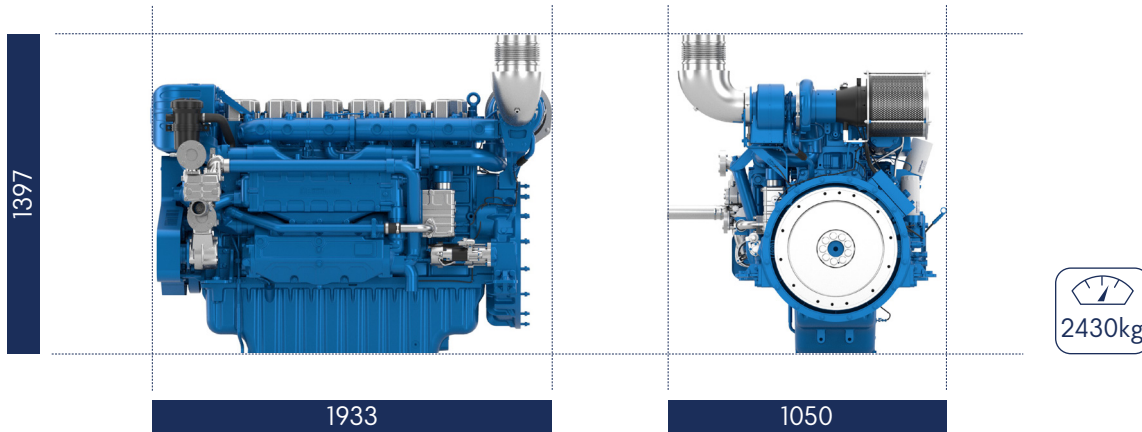

	P1	P2	P3	P4
Application	Unrestricted	Continuous (Heavy)	Intermittent	Light
Engine load variations	Not important	Important	Important	Very important
Average Engine load factor	80-100%	30-80%	60%	60%
Annual working time	5000 - 7000h	3000-5000h	1000-3000h	Less than 1500h
Time at full load	12h each 12h	8h each 12h	2h each 12h	1h each 12h

P1 Continuous Duty

- Deep sea trawlers
- Shrimps trawlers
- Sea going tug boats
- River tug boats
- Push boats
- Freighters
- Dredges
- LCT
- Ferries

P2 Heavy Duty

- Deep sea trawlers
- Shrimps trawlers
- Sea going tug boats
- River tug boats
- Push boats
- Freighters
- Dredges
- LCT
- Ferries

P3 Intermittent Duty

- Seasonal passenger vessels
- Fishing boats
- Pilot boats
- Commercial pleasure boats
- Pump boats
- Displacement sailboats
- Trawlers
- Bow thrusters

P4 Light Duty

- Private pleasure boats
- Multi-hull pleasure boats
- Survey or rescue fast vessels
- Military fast vessels.

P5 High performance Duty

- Private pleasure boats
- Multi-hull pleasure boats

Standard equipment

Engine & Block	Cast iron cylinder block, with replaceable cylinder liners Separate cast iron cylinder heads Replaceable valves guides and seats Steel forged crankshaft with 7 bearings Lube oil cooled light steel piston with 3 high performance piston rings
Cooling System	Two - stage cooling circuit with built - in HT thermostatic valve Integrated fresh water expansion tank High efficiency tubular heat exchanger Belt driven centrifugal fresh water pump Self priming raw water pump with bronze impeller
Lubrication System	Full flow lube oil filters duplex type Fresh water cooled lube oil heat exchanger Electrical draining and pre-lub pump
Fuel System	Common-rail electronic injection High pressure pump with shielded high pressure injection rail and pipes Fuel oil filter duplex type
Intake Air and Exhaust System	Double flow raw water cooled intake air heat exchanger module High efficiency dry turbocharger with ball bearing technology
Electrical System	Voltage: 24V DC insulated Electrical starter 190A battery alternator

Optional Equipment	Keel Cooling configuration 1400N.m front PTO with elastic coupling Additional pulley Elastic mounting Closed circuit blow by filtration Air starter Fresh water pre-heater Cabin heating connections Master BMS for full class engines Additional displays
---------------------------	---

Performance

P1 552@1600rpm

Torque

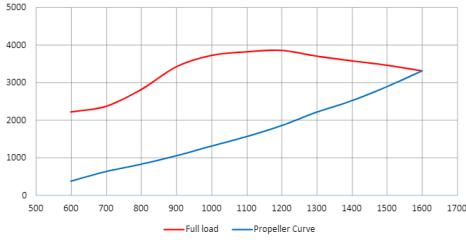

Power

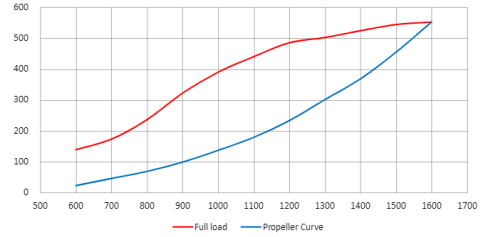

BSFC (L/h)

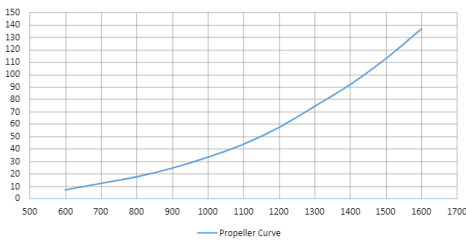

BSFC (g/kWh)

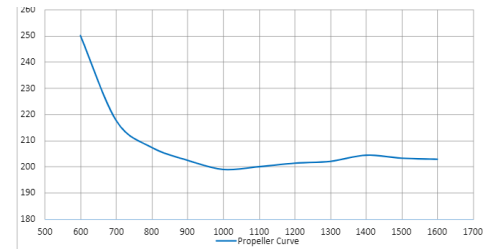

P1 552@1800rpm

Torque

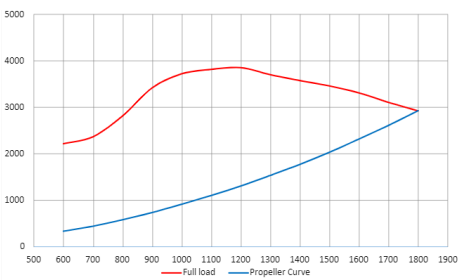

Power

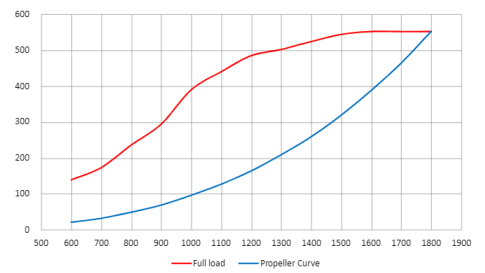

BSFC (L/h)

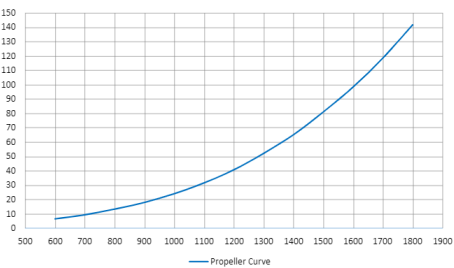

BSFC (g/kWh)

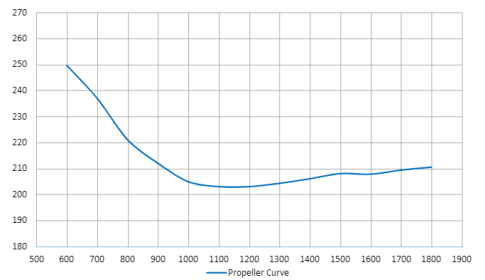

Performance

P2 574@1600rpm

Torque

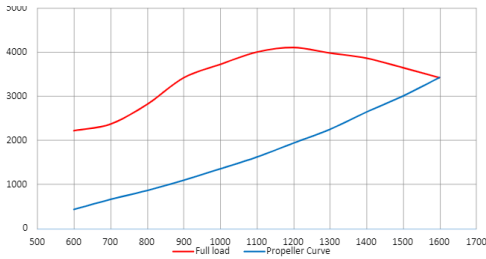

Power

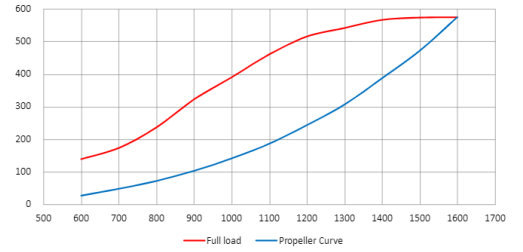

BSFC (L/h)

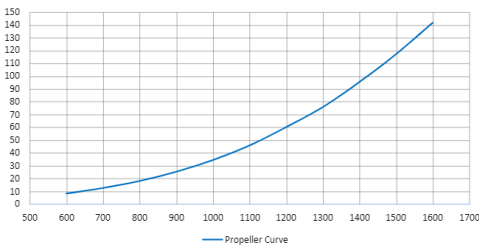

BSFC (g/kWh)

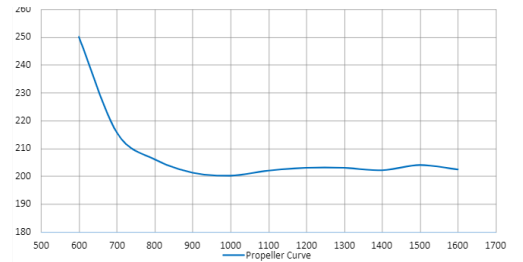

P2 574@1800rpm

Torque

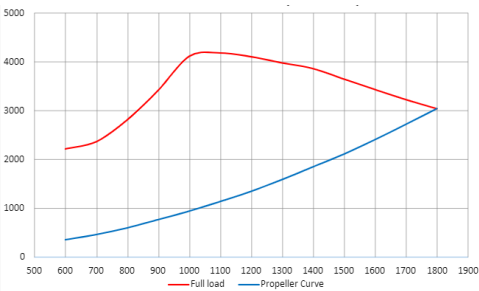

Power

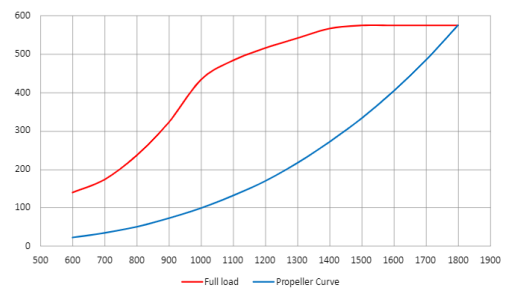

BSFC (L/h)

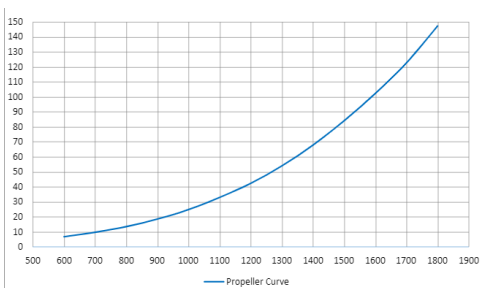

BSFC (g/kWh)

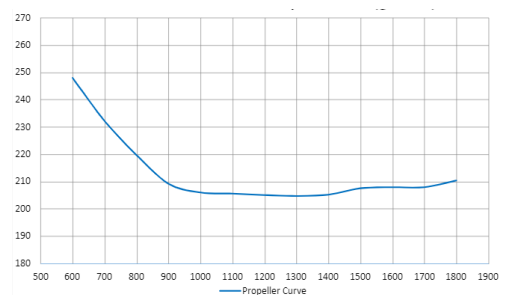

Performance

P3 670@1900rpm

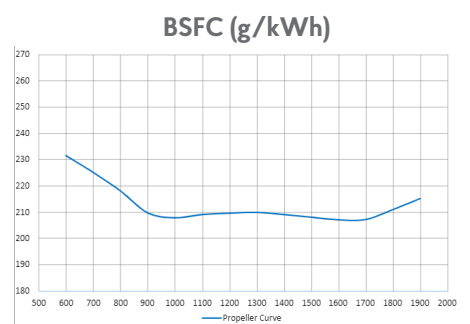
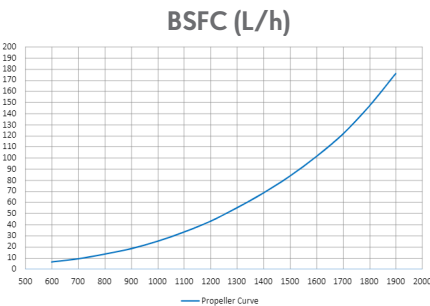
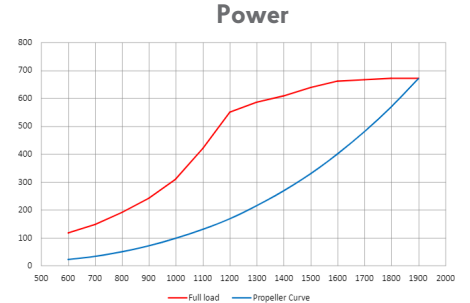
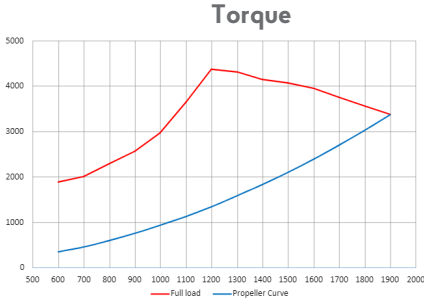

P4 750@2000rpm

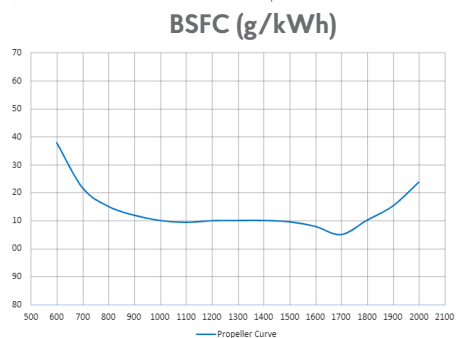
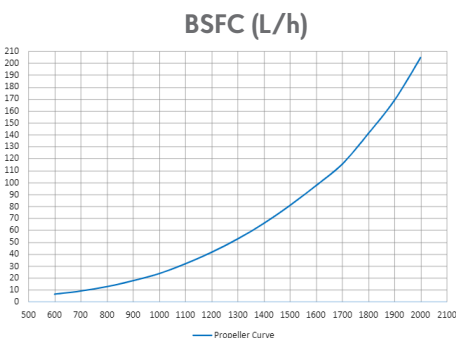
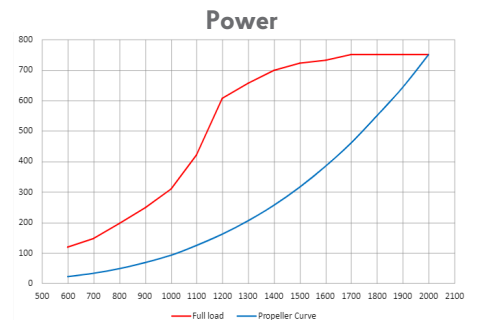
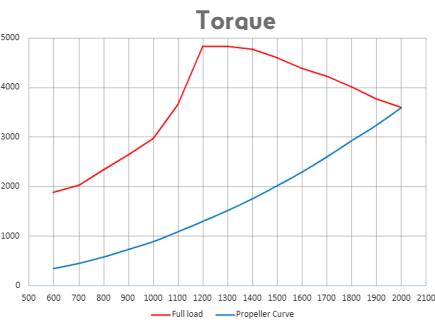

Power definition

(Standard ISO 3046/1 - 1995 (F))

Reference conditions

Ambient temperature	25°C / 77°F
Barometric pressure	100 kPa
Relative humidity	30%R
Raw water temperature	25°C / 77°F

Fuel oil

Relative density	0,840 ± 0,005
Lower calorific power	42 700 kJ/kg
Consumption tolerances	+ 5%
	(DIN ISO 3046-1)
Inlet limit temperature	35°C / 95°F

Our ratings also comply with classification societies maximum temperature definition without power derating.

Ambient temperature	45°C / 113°F
Raw water temperature	32°C / 90°F

 **MOTEURS**
Baudouin



Baudouin.com