

6M33.3

Common rail diesel engine, 2-stage turbocharging

Common rail diesel engine,
2-stage turbocharging

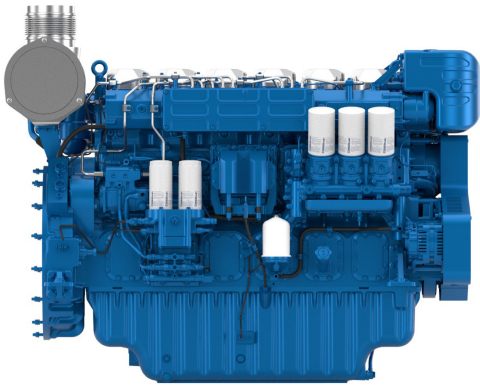

Number of cylinders	6
Bore and stroke (mm)	150 x 185
Total displacement (L)	19.8
Engine rotation	counter clockwise
Idle speed	700
Flywheel	18"
Flywheel housing	SAE 0

Customer benefits

Adheres to strict emission regulations and competitive performance as it is equipped with Most advanced common rail technology and high end injection system (2200 bar)

Efficient fuel consumption, thanks to the highly efficient turbochargers

Easy maintenance due to individual cylinder heads

Highly reliable key components ensuring longevity

Life cycle cost efficiency with extended mean time between overhauls

Rated power - Fuel consumption

Duty	kW	HP	RPM	Fuel consumption			IMO	EPA
				Optimum value	Rated power			
				g/kWh	g/kWh	l/h		
P1	552	720	1600	200	135	198	II - III	NO
	552	780	1800	203	136	201	II - III	NO
P2	574	800	1600	199	139	198	II - III	NO
	574	850	1800	201	141	200	II - III	NO
P3	670	911	1900	219	179	205	II - III	NO
P4	750	1020	2000	222	203	201	II - III	NO

	P1	P2	P3	P4
Application	Unrestricted	Heavy	Intermittent	Light
Engine load variations	Not important	Important	Important	Very important
Average Engine load factor	80-100%	30-80%	60%	30%
Annual working time	5000 - 7000h	3000-5000h	1000-3000h	Less than 1500h
Time at full load	Unlimited	8h each 12h	2h each 12h	1h each 12h

P1 Continuous Duty

- Deep sea trawlers
- Shrimps trawlers
- Sea going tug boats
- River tug boats
- Push boats
- Freighters
- Dredges
- LCT
- Ferries

P2 Heavy Duty

- Deep sea trawlers
- Shrimps trawlers
- Sea going tug boats
- River tug boats
- Push boats
- Freighters
- Dredges
- LCT
- Ferries

P3 Intermittent Duty

- Seasonal passenger vessels
- Fishing boats
- Pilot boats
- Commercial pleasure boats
- Pump boats
- Displacement sailboats
- Trawlers
- Bow thrusters

P4 Light Duty

- Private pleasure boats
- Multi-hull pleasure boats
- Survey or rescue fast vessels
- Military fast vessels.

P5 High performance Duty

- Private pleasure boats
- Multi-hull pleasure boats

Dimensions and dry weight (mm/kg)

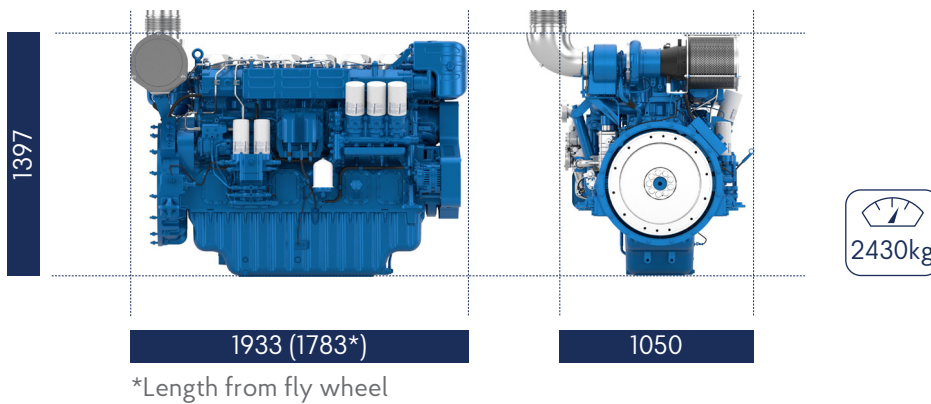

Standard equipment

Cooling System

- Two - stage cooling circuit with built - in HT thermostatic valve
- Integrated fresh water expansion tank
- High efficiency tubular heat exchanger
- Belt driven centrifugal fresh water pump
- Self priming raw water pump with bronze impeller

Lubrication System

- Full flow lube oil filters duplex type
- Fresh water cooled lube oil heat exchanger
- Electrical draining and pre-lub pump

Fuel System

- Common-rail injection
- High pressure pump with shielded high pressure injection rail and pipes
- Fuel oil filter duplex type
- External fuel pre-filter with water separator

Intake Air and Exhaust System

- Double flow raw water cooled intake air heat exchanger module
- High efficiency dry turbocharger with ball bearing technology

Electrical System

- Voltage: 24V DC insulated
- Electrical starter
- 200A battery alternator
- ECO BMS with IV12 display

Optional Equipment

- Thermostatic valve on raw water circuit
- Keel cooling
- Raw water connections PN standard
- Fresh water pre-heater
- Cabin heating connections
- 1400N.m Front PTO with elastic coupling
- Additional pulley
- Elastic mounting
- Closed circuit blow by filtration
- Air starter
- Master BMS for full class engines
- Additional displays

Performance

6M33.3 P1 552@1600rpm - Torque

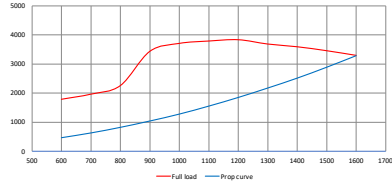

6M33.3 P1 552@1800rpm - Torque

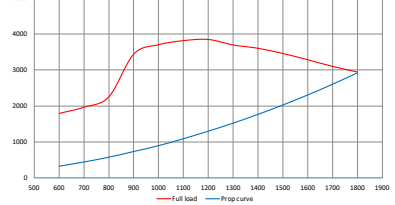

6M33.3 P2 574@1600rpm - Torque

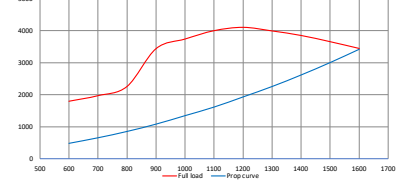

6M33.3 P1 552@1600 - Power

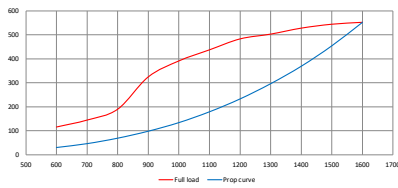

6M33.3 P1 552@1800rpm - Power

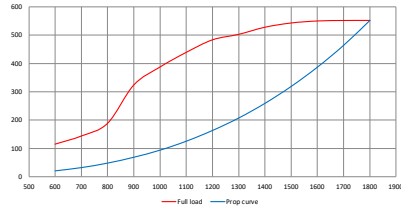

6M33.3 P2 574@1600rpm - Power

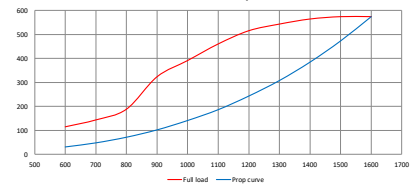

6M33.3 P1 552@1600 - BSFC (g/kWh)

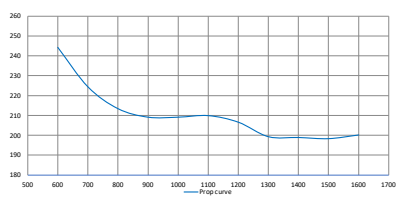

6M33.3 P1 552@1800rpm - BSFC (g/kWh)

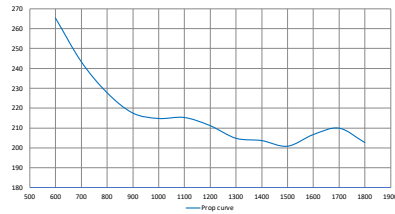

6M33.3 P2 574@1600rpm - BSFC (g/kWh)

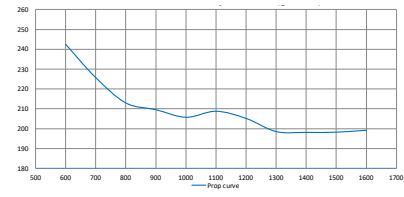

6M33.3 P1 552@1600 - BSFC (L/h)

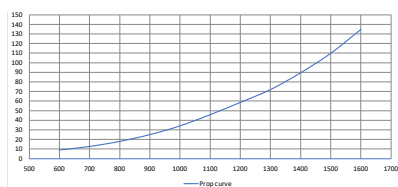

6M33.3 P1 552@1800rpm - BSFC (L/h)

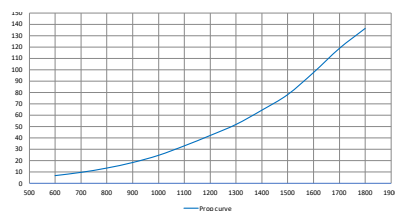

6M33.3 P2 574@1600rpm - BSFC (L/h)

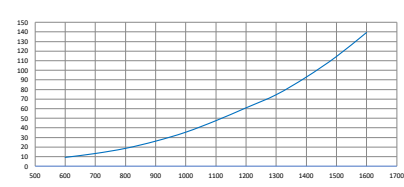

Performance

6M33.3 P2 574@1800rpm - Torque

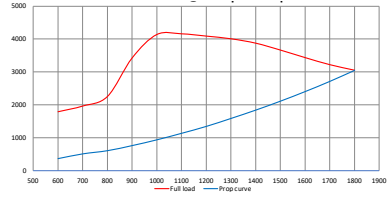

6M33.3 P3 670@1900rpm - Torque

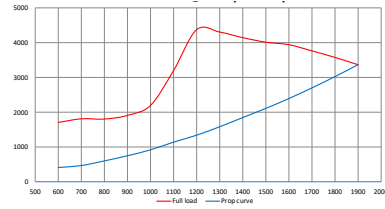

6M33.3 P4 750@2000rpm - Torque

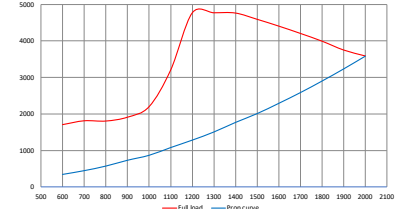

6M33.3 P2 574@1800rpm - Power

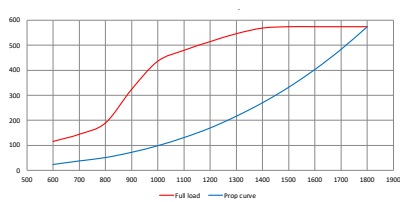

6M33.3 P3 670@1900rpm - Power

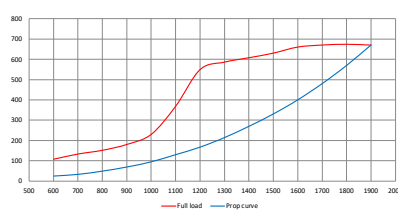

6M33.3 P4 750@2000rpm - Power

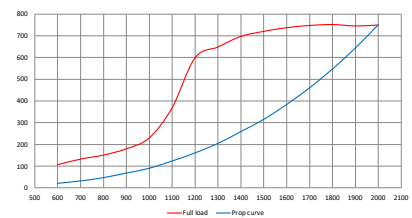

6M33.3 P2 574@1800rpm - BSFC (g/kWh)

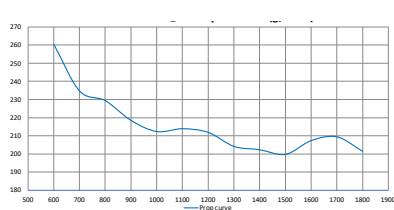

6M33.3 P3 670@1900rpm - BSFC (g/kWh)

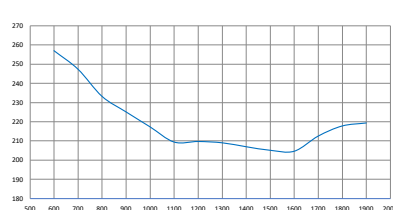

6M33.3 P4 750@2000rpm - BSFC (g/kWh)

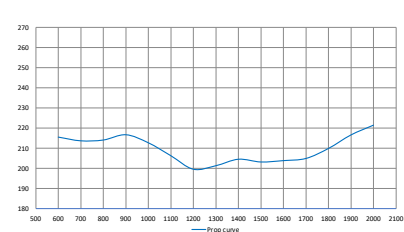

6M33.3 P2 574@1800rpm - BSFC (L/h)

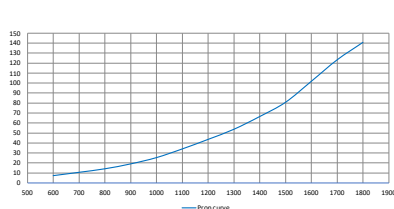

6M33.3 P3 670@1900rpm - BSFC (L/h)

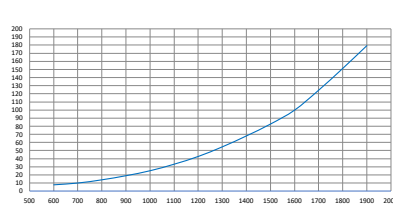

6M33.3 P4 750@2000rpm - BSFC (L/h)

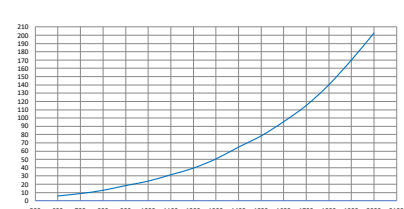

Power definition

(Standard ISO 3046/1 - 1995 (F))

Reference conditions

Ambient temperature	25°C / 77°F
Barometric pressure	100 kPa
Relative humidity	30%R
Raw water temperature	25°C / 77°F

Fuel oil

Relative density	0,840 ± 0,005
Lower calorific power	42 700 kJ/kg
Consumption tolerances	+ 5%
	(DIN ISO 3046-1)
Inlet limit temperature	35°C / 95°F

Our ratings also comply with classification societies maximum temperature definition without power derating.

Ambient temperature	45°C / 113°F
Raw water temperature	32°C / 90°F