

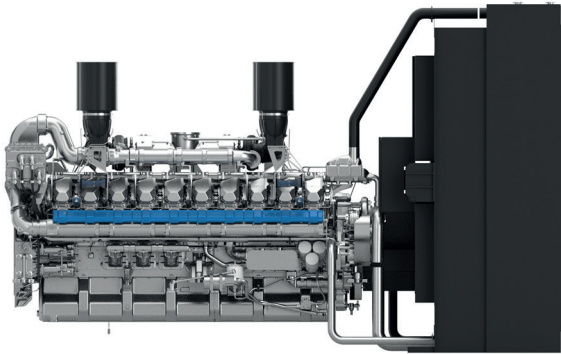

20M33

PowerKit ESP/PRP/DCP Diesel Engine



Bore & Stroke (mm)	150 x 185
Displacement (L)	65.4 L
N° of Cylinders	20
Cylinders Arrangement	At Vee
Fuel System	High Pressure Common Rail
Governor (Gov.)	ECU
Aspiration (Asp.)	T/A-A

Customer benefits

Warranty terms - 2 yrs unlimited hours PRP, 4 yrs / 800 ESP
 50°C Cooling package standard with low derating
 Extended MTBO

ESP/PRP/DCP Diesel Engine Models	Gross Engine Output			Typical Generator Output						RPM	Asp.	Gov.
	ESP	PRP	DCP	ESP		PRP		DCP				
				kWm	kWe	kVA	kWe	kVA	kWe			
20M33G2250/5	2020	1850	1850	1800	2250	1600	2000	1600	2000	1500	T/A-W	ECU
20M33G2500/5^	2210	2010		2000	2500	1800	2250			1500	T/A-W	ECU
20M33G2000/6	2230	2027	2027	2000	2500	1800	2250	1800	2250	1800	T/A-W	ECU
20M33G2200/6^	2460	2240		2200	2750	2000	2500			1800	T/A-W	ECU

Standard Equipment

Engine and block	Cast iron cylinder block with inspection door per cylinder Cast iron cylinder liners, wet type and replaceable valves guides and seats Separate cast iron cylinder heads with 4 valves Hardened steel forged crankshaft with induction hardened journals, crankpins and radius Lube oil cooled light alloy pistons with high performance piston rings
Cooling System	Radiator and hoses supplied separately Two separate circuits High temperature circuit equipped with thermostatically-controlled system with two gear driven coolant pumps Low temperature circuit equipped with belt driven coolant pump
Lubrication system	Full flow screw able oil filters Lube oil purifier with replaceable cartridge Water cooled lube oil cooler
Fuel system	High pressure common rail system with one high pressure pump gear driven in the V angle of cylinder block Two rails mounted on the sides of the engine, double wall, under inlet manifold Duplex fine filter and water separation filter assembly with transparent cup for better efficiency Electric fuel priming pump integrated in the filters support Special rear mounted air filter with restriction indicator Exhaust manifold shield for heat isolating
Air intake and exhaust system	The 4 compressors are feeding a single water-air intercooler, mounted over the exhaust system flywheel housing, with vertical flow Special rear mounted air filter with restriction indicator Exhaust manifold and turbocharger shield for heat isolating
Electrical System	24V DC electric starter motor and battery charging alternator Low oil pressure & high water temperature sensors
Flywheel and housing	SAE 00 flywheel housing and 21" flywheel

Dimensions and dry weight (mm/kg)

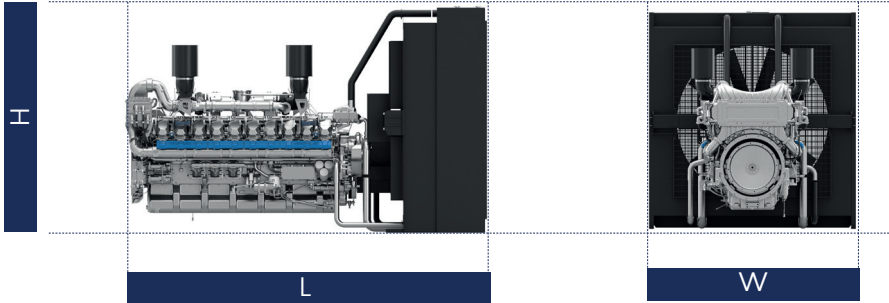

Diesel Engine	Speed RPM	Dimensions and dry weight including radiator			
		L mm	W mm	H mm	Weight Kg
20M33G2250/5 [^]	1500	4611	2756	2870	8275
20M33G2500/5 [^]	1500	4611	2756	2870	8275
20M33G2000/6	1800	4611	2756	2870	8295
20M33G2200/6 [^]	1800	4611	2756	2870	8295

Ratings definitions

Emergency Standby Power (ESP)

Emergency Standby Power is the maximum power available for a varying load for the duration of a main power network failure. The average load factor over 24 hours of operation should not exceed 70% of the engine's ESP power rating. Typical operational hours of the engine is 200 hours per year, with a maximum usage of 500 hours per year. This includes an annual maximum of 25 hours per year at the ESP power rating. No overload capability is allowed. The engine is not to be used for sustained utility paralleling applications.

DCP

Data Centre Power is defined as being the maximum power which a generating set is capable of delivering while supplying a variable or continuous electrical load and during unlimited run hours. Depending on the sites to supply and the availability of reliable utility, the generating set manufacturer is responsible to define what power level he is able to supply to fulfil that requirement including hardware or software or maintenance plan adaptation.

Unlimited Prime Rated Power (PRP)

Prime Power is the maximum power available for unlimited hours of usage in a variable load application. The average load factor should not exceed 70% of the engine's PRP power rating during any 24 hour period. An overload capability of 10% is available, however, this is limited to 1 hour within every 12 hour period.

- 1) All ratings are based on operating conditions under ISO 8528-1, ISO 3046, DIN6271. Performance tolerance of $\pm 5\%$.
- 2) Test conditions: 100 kPa, 25°C air inlet temperature, relative humidity of 30%, with fuel density 0.84 kg/L.
Derating may be required for conditions outside these; please contact the factory for details.
- 3) Power output curves are based on the engine operating with fuel system, water pump and lubricating oil pump; not included are battery charging alternator, fan and optional equipment.

